

6. Operation and maintenance

Remove and clean the filter cartridge (9) in case of an increasing pressure loss and a decreasing flow rate, but at least annually the cartridge has to be cleaned. Damaged filter cartridges have to be changed.

The filter cartridge (9) has to be removed under unpressurised condition: Close the shut-off valve in the supply line of the filter, open high pressure valve (3) beneath the filter, so that the gas in the filter escapes in to the atmosphere.

! Application of Oxygen: After long time usage filtered particles clog the filter cartridge. Thus the filtering surface, resp. the sectional area of the filter is reduced and the pressure loss D_p increases. To ensure a continuous gas flow, enlarge the pressure difference of inlet and outlet pressure. Avoid a higher flow rate of oxygen in the filter and the risk of a burn out/internal ignition, by blowing off the filter cartridges (9) periodical. Attention has to be paid to UVV "oxygen" (BGV B7 [VBG 62])!

6.1 Remove filter cartridge (9) under unpressurised condition: Close shut-off valve and open high pressure valve (3).

6.2 Remove the high pressure valve (3), loosen union nut (5) (SW 70) and remove plug (4) with the o-ring (6) and the pressure spring (7). After that take out and clean the filter cartridge. Damaged filter cartridges have to be changed.

Install the system in reverse succession and perform a testing of the leakage with a useful method (e.g. leak tightness spray) after the installation.

Advice: In case of flammable gases conduct purge valve connection outside.

7. Repair

- 7.1 Repairs may only be carried out in authorized repair workshops by expert persons.
- 7.2 Only original spare parts must be used. The materials have been adapted to the gas type in each instance. So always specify the gas type.
- 7.3 In case of independent repairs, the use of non-original spare parts or changes on the side of the user or a third party without the approval of the manufacturer, any form of liability for resulting damages will expire as well as the manufacturers warranty.
- 7.4 After being repaired, the pressure regulator must be checked with respect to proper function, leak-tightness and cleanliness of the gas-wetted surfaces. When the system is used again, a sufficient purging operation must be carried out first.

Instructions for use F25 Filter for 200 bar

spectrotec

Contents

	page
1 Application	1
1.1 Designated use	1
1.2 Non-designated use	1
1.3 Technical data	2
2. Safety instructions	2
3. Labeling	2
4 Start up	3
5 Operation and maintenance	3
6 Shut down	4
7 Repair	4



1. Application

1.1 Designated use
Use the filter F25 to prevent particles such as rust, sand and chips entering the system. Ensure with the filter F25 a long operational life span of the following components.



1.2 Non-designated use
Do not use the filter alternately for different gas types.
The filter must not be contaminated by high amounts of dust, salt and acid or other corrosive particles. Ask your local MESSER dealer for further information.



Do not use the filter for unsuitable or corrosive gas types.
Do not use at temperatures below -30°C or above $+60^{\circ}\text{C}$.



The system has to be used according to these instructions for use and especially the safety instructions!

1.3 Technical data

Inlet pressure:	max. 200 bar
Flow rate:	max. 40 m ³ /h (operating m ³)
	The flow rate for oxygen is in
	operating m ³ = $\frac{\text{m}^3/\text{h} (1 \text{ bar}, 15^\circ\text{C})}{\text{bar (absolute pressure)}}$
Materials:	- body:brass
	- filter cartridge: powdered metal bronze
Pores:	width of pore: 10 - 25 µm, square of filter: 24 cm ²
Weight:	10,3 kg
Supplies:	DN 25 (inside diameter pipe)
	in- and outlet G 1 1/2" internal thread
Article No.:	oxygen: 509.60250
	neutral gases: 512.60250

2. Safety instructions

- 2.1 All items of informations marked with ▲ are valid as special safety instructions.
- 2.2 This filter adheres to state-of-the-art technology and to the demands of the existing standards and regulations.
- 2.3 Changes or modifications are not allowed to be made to the filter without the prior consent of the manufacturer.
- 2.4 The equipment must be operated by suitable trained personnel only.
- 2.5 The result of improper handling and improper use as intended can involve risks for the user and other persons as well as damage to the device.
- 2.6 Regulations to be adhered to:
 - BGV A1 (VBG 1), "General Specifications"
 - BGV D1 (VBG 15), "Welding, Cutting and Related Procedures"
 - BGV B6 (VBG 61), "Gases"
 - BGV B7 (VBG 62), "Oxygen"
 - Technical Rules for Liquid Gas
 - TRAC 207



Special attention has to be paid to the country specific laws, regulations and procedures concerning the use of this type of equipment.



- 2.7 Use only for gas types the filter is labelled for (see item 3).



- 2.8 Do not use at temperatures below -30°C or above +60°C.



- 2.9 The valve has always to be opened slowly!



- 2.10 All parts coming into contact with oxygen must be kept in oil-free and grease-free condition.



Fire or explosion hazard!



- 2.11 Smoking or open fire (e.g. candles) in the vicinity of the gas supply system is strictly prohibited.



Fire and explosion hazard!

3. Labelling

- 1 type of filter
- 2 gas type
- 3 article no.
- 4 max. inlet pressure
- 5 date of manufacture

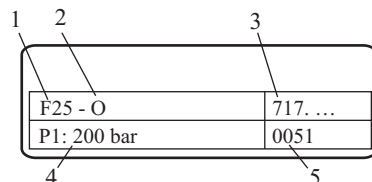

4. Installation

- 4.1 Mount the filter in the supply line as close as possible to the fittings, that have to be protected.
- 4.2 Fittings: There are internal threads, to connect the tubes and fittings directly with the in- and outlet. Connections which enable a fast installation and removing are recommended.

5. Start-up

- 5.1 The information in these instructions for use is to be read before beginning work and to be observed during the work.
- 5.2 Check whether the filter is identified for the type of gas present. If the gas type does not agree, identify with the enclosed gas identification plate in accordance with the instructions.

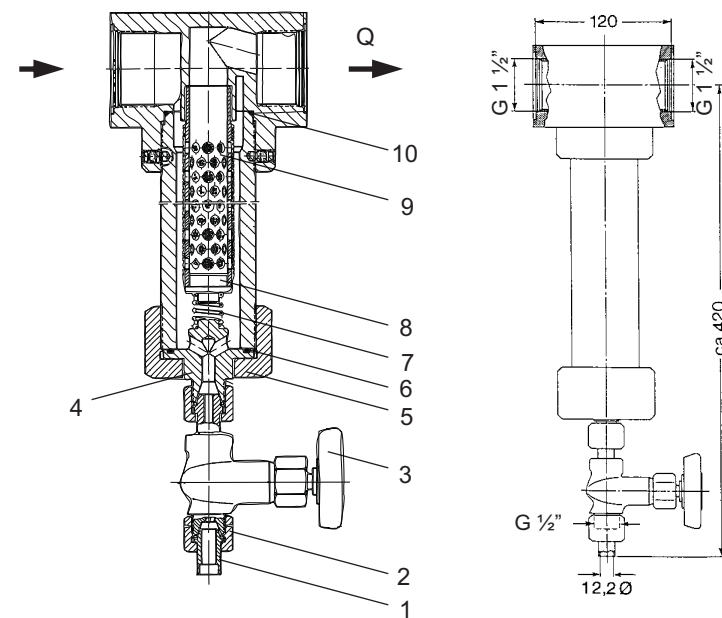

- | | |
|-----------------------|--------------------|
| 1 soldering nipple | 6 o-ring |
| 2 union nut | 7 pressure spring |
| 3 high pressure valve | 8 blanking plug |
| 4 plug | 9 filter cartridge |
| 5 union nut | 10 o-ring |