

User manual
Pressure control panel
BT2000AC

Table of contents

1 Introduction	4
2 Description	5
2.1 Intended use	5
2.2 Misuse	5
2.3 Identification / label	5
2.4 Environment.....	6
2.4.1 Temperatures.....	6
2.4.2 Degree of cleanliness	6
2.4.3 Emissions.....	6
2.5 Standards and laws	6
3 Safety	8
3.1 Basic information on the safety instructions	8
3.2 Safety instructions	9
3.3 Emergencies and safety devices	11
3.4 Qualification of the operating and maintenance personnel.....	11
4 Design and function	13
4.1 Design.....	13
4.2 Functional description.....	14
4.3 Technical data	15
4.4 Boundaries and interfaces	16
5 Installation	17
5.1 General information	17
5.2 Installation work	17
5.2.1 Installation.....	17
5.2.2 Connecting the incoming and outgoing lines	17
5.3 Checking the system	17
5.3.1 Pressure test with purge gas	17
6 Commissioning	19
6.1 Preparations for commissioning	19
6.2 Procedure for commissioning	19
6.2.1 Connecting the process gas source.....	19
7 Operation	20
7.1 General information on operation	20
7.2 Gas supply interruption.....	20
7.2.1 Interruptions to operation for less than 48 hours	20
7.2.2 Interruptions to operation for more than 48 hours.....	20
7.2.3 Putting the pressure control panel into a safe condition	20
7.3 Exchanging the process gas source.....	21
8 Maintenance, cleaning and repairs	22
8.1 General information on maintenance.....	22
8.2 Flushing the process gas into the pressure control panel	23
8.3 Regular maintenance work and cleaning.....	24
9 Repair	25

9.1	General information on repair work	25
9.2	Troubleshooting and fault rectification	26
10	Decommissioning and recommissioning	27
10.1	Decommissioning	27
10.2	Recommissioning	27
11	Dismantling and disposal	28
11.1	General information on dismantling	28
11.2	Returns	29
11.3	Disposal	29

1 Introduction

This user manual is the original user manual for the Pressure control panel BT2000AC from Spectron Gas Control Systems GmbH (Fritz-Klatte-Str. 8, D-65933 Frankfurt), referred to as Spectron.

The user manual is intended to facilitate correct and safe operation for the operating firm, and to warn against misuse. It is intended for the qualified personnel and the operator of the facility.



WARNING

Incorrect operation

Incorrect operation of the system, e.g. due to instruction errors, can lead to personal injury or damage to the system.

- a) Access to the user manual by the operating and maintenance personnel must be absolutely ensured at all times.
- b) A copy of the system documentation including the user manual must therefore be kept either on the system or in a suitable and accessible location.

This user manual contains information protected by copyright law. It must not be photocopied, reproduced, translated or copied onto data carriers, either in full or in part, without prior authorisation. Spectron retains all further rights.

2 Description

2.1 Intended use

The intended use of the Pressure control panel BT2000AC is the expansion of a gas from a gas source and the distribution of the gas with adjustable outlet pressure.

Pressure control panels of type BT2000AC are only suitable for gaseous acetylene (ethyne) of commercial purity. During gas extraction, the maximum extraction quantity prescribed by the gas supplier must not be exceeded, as solvents can otherwise be introduced into the product.

The permissible gas types and pressure ranges are each specified on the label (see "Identification / label").

The equipment versions of the Pressure control panels without electrical components may be used in an explosion hazard zone as they do not have separate ignition sources (ignition hazard assessment according to DIN EN ISO 80079-36).

Pressure control panels with electrical components that are suitable for use in an explosion hazard zone are marked on the label according to EU Directive 2014/34/EU.

To be able to use the Pressure control panels as intended, all persons working with it must comply with the specifications of the relevant user manual.

The area in which hazards can occur when used as intended is the area around the Pressure control panels. The danger zone changes depending on the system status and use.

2.2 Misuse

Any improper use constitutes misuse. Pressure control panels may only be used for the specified gases and in the specified pressure range. Pressure control panels with electrical components without marking according to EU Directive 2014/34/EU may not be used in an explosion hazard zone.

Furthermore, the following operating conditions are regarded as misuse:

- Use for gases in their liquid phase
- Failure to carry out inspection and maintenance work
- Pressurisation in reverse (opposite to the flow direction)
- Operation with gases that are not specified on the label
- Operation outside the permissible technical limit values
- Failure to heed and comply with any applicable legal regulations and other provisions
- Non-observance of the user manual
- Failure to heed the information on the label and in the product data sheet

2.3 Identification / label

The label is located on the on the mounting plate of the Pressure control panel.

The label provides the following details:

Details	Example
Manufacturer	Spectron Gas Control Systems GmbH
Date of manufacture	2020/08
Standard	ISO 14114:2017 / 15615:2013 / 5175-1
Project number	PROJECT
Article description	BT2000AC-1x1-0-SSE-M-SV-FS2
Inlet pressure P1	25 bar

Outlet pressure P2	1.5 bar
Gas type	Acetylene (C ₂ H ₂)
Flow rate Qmax	1 m ³ /h
Temperature range	-20 ... +60°C
Pcheck test pressure	25 bar

2.4 Environment

2.4.1 Temperatures

Normal temperatures expected in a production area are assumed when operating the system: -20°C to +60°C.

The air humidity must be below 60 % rel. humidity to prevent condensation. The operating temperature depends on the gas used.

2.4.2 Degree of cleanliness

Access to the system and to the escape and rescue routes must not be blocked.

The product should be kept clean (dust-free).

A suitable purge gas must be used, taking into account the quality and properties of the process gas.

Compressed air must be used for the control air at least class 5 according to ISO 8573-1.

2.4.3 Emissions

The A-rated sound pressure level does not exceed the value of 70 dB(A). It is not necessary to wear hearing protection.

The waste gas line or a burst disc line must not end in areas where the escaping process gas poses a hazard to persons or the environment.

Further emissions in the form of vibrations, radiation, vapours, dusts and waste water do not occur in the regular operation of the product.

2.5 Standards and laws

The design and construction of the pressure control panel is subject to the following standards and directives:

2006/42/EC	Machinery Directive
2014/68/EU	Pressure Equipment Directive
2014/34/EU	ATEX directives
98/24/EC	Hazardous Substances Directive
DIN EN ISO 12100:2010	Safety of Machinery
Safety data sheet for the gases used	Process gas and auxiliary media

Various **additional** laws, regulations and guidelines must be complied with when handling pressurised gases. Find out about the laws, regulations and guidelines that apply in your location.

BetrSichV	<i>Betriebssicherheitsverordnung</i> (Industrial health and safety ordinance)
ProdSG	<i>Produktsicherheitsgesetz</i> (Product Safety Law)
GefStoffV	<i>Gefahrstoffverordnung</i> (Hazardous Substances Ordinance)

TRGS 400, 407, 500, 720, 721, 722, 727, 745,746	<i>Technische Regeln Betriebssicherheit</i> (Technical Regulations on Operational Safety)
TRBS 1111, 2152, 3145, 3146	<i>Technische Regeln Betriebssicherheit</i> (Technical Regulations on Operational Safety)
TRAS	<i>Technische Regeln Anlagensicherheit</i> (Technical Regulations on Plant Safety)
DGUV Regulation 1	German Trade Association Principles of Prevention
DGUV Rule 113-001	German Trade Association Rules on Explosion Protection
DGUV Rule 100-500 Chapter 2.26	Accident prevention regulations on welding, cutting and allied processes
DGUV Rule 100-500 Chapter 2.31	Accident prevention regulation on gas lines
EIGA documents	
DIN EN ISO 14114-2017	General requirements for gas welding equipment, acetylene manifold systems, battery systems for welding, cutting and allied processes
DIN EN ISO 5175-1	Safety devices with integrated flame arrestor
DIN EN ISO 15615	Safety devices for high-pressure equipment

3 Safety

3.1 Basic information on the safety instructions

The product complies with the recognised technical regulations. Nevertheless, knowledge of the media used and their dangers as well as basic knowledge of the pressure control panel are prerequisites for safe and accident-free operation.

The user manual must be read and understood by every user. Instruction must be documented in writing.

The safety instructions are to be regarded as a supplement to the applicable accident prevention regulations and laws. Existing accident prevention regulations and laws must be observed in all cases.



NOTICE

Hazards from the operating environment of the system can lead to injuries to persons.

- a) No changes may be made to the system which result in a change in function.
- b) It is not possible to outline and cover in this manual all hazards arising from the environment or unforeseeable operating conditions of the system.

In the Safety Instructions chapter:

- Users are informed regarding hazards, residual risks and measures for risk reduction.
- The presentation of the safety instructions and the symbols is explained.
- Basic safety instructions to be observed in general are listed. Specific safety instructions are listed in the relevant chapters.



⚠ DANGER

DANGER indicates an imminent danger. If not avoided, death or extremely serious injuries will result.



⚠ WARNING

WARNING indicates a potential imminent danger. If not avoided, death or serious injury could result.



⚠ CAUTION

CAUTION indicates a potentially imminent danger. If not avoided, minor or moderate injury could result.



NOTICE

NOTICE indicates a potentially harmful situation. If not avoided, the system or property in its vicinity could be damaged.

3.2 Safety instructions

The safety instructions are to be observed by all persons working on the system. The rules and regulations for accident prevention applicable to the place of use are to be observed. The instruction of the operating and maintenance personnel on system safety must be documented.

Please pay special attention to this chapter to avoid accidents.

All measures and specifications in the safety data sheets must be implemented and observed.



DANGER

Gas leaks

If gas escapes on the product, contamination of persons, fires or explosions or the displacement of atmospheric oxygen can occur! Serious or fatal injuries are possible.

- a) Do not place pipelines and fittings under mechanical stress. Never use pipelines and components as climbing aid or to secure other parts!
- b) In the event of leaks, immediately secure the affected area!
- c) Smoking and naked flame are strictly prohibited!



DANGER

Intended use

Operation of the product with gases other than those specified or outside the limits may result in dangerous reactions in the system. Incorrect use poses considerable risks to operating personnel and the environment!

- a) Only use the product for gases for which it was designed.
- b) Only use the product in the specified limit values for pressure and withdrawal quantity.
- c) Usage for another type of gas or outside the limit values is prohibited and constitutes misuse.



DANGER

Defective product

A defect on the product can result in unforeseeable operating conditions. Persons may be injured.

- a) The product may only be operated in technically perfect condition in compliance with all chapters of the user manual.
- b) Environmental protection laws and safety regulations must be observed.



WARNING

Displacement of atmospheric oxygen

In the event of inert gas leaks, displacement of atmospheric oxygen may occur. Danger of suffocation!

- a) The operator must ensure adequate ventilation and airing in all rooms with gas installations and monitor the oxygen content.



⚠ WARNING

Repairs

If the product is not used as intended, unpredictable operating conditions may occur. Serious personal injuries are possible.

- a) Repairs may not lead to a change in function. The system may not be tampered with or modified.
- b) Before each repair, the system must be depressurised and flushed through.
- c) Repairs are only permitted to be carried out by trained persons.



⚠ WARNING

Incorrect operation

Incorrect operation of the system, e.g. due to instruction errors, can lead to personal injury or damage to the system.

- a) Access to the user manual by the operating and maintenance personnel must be absolutely ensured at all times.
- b) A copy of the system documentation including the user manual must therefore be kept either on the system or in a suitable and accessible location.



⚠ WARNING

Working on the product

If an accident occurs when working on the product, there is a considerable risk of injury.

- a) Never work on the product unattended or unannounced.
- b) Observe the site safety rules and permission procedure.



⚠ WARNING

Maintenance

Incorrect maintenance or maintenance work performed at the incorrect time can result in damage to the system or injury to persons.

- a) To avoid static charges, do not clean the product using dry cloths. Use damp cotton cloths.
- b) The maintenance intervals are to be specified by the system operator as part of its risk assessment.
- c) Observe the maintenance intervals and maintenance guidelines from the manufacturer and the applicable guidelines.
- d) Components may only be replaced by spare parts of the same design. The specifications of the component manufacturers must be complied with during installation.



⚠ CAUTION

Pressure relief lines

Discharge of hazardous media at the end of a pressure relief line or exhaust air line.

- a) Pressure relief lines may not end in areas where the escaping process gas poses a hazard to persons or the environment.
- b) The position of the pressure relief line must be carefully checked taking into account the material properties, main wind direction and other conditions.



NOTICE

Lighting

Incorrect switching actions or confusion can occur due to inadequate lighting.

- a) Ensure sufficient lighting in accordance with the statutory regulations.

3.3 Emergencies and safety devices

The operational local safety regulations of the system operator, such as the alarm plan, fire safety regulations and the escape and rescue plans, apply in all cases for the operation of the Pressure control panel.

When handling gases, all specifications from the safety data sheets must be followed. Local emergency services should be informed of the gases used at the site of the system.

In the event of mechanical damage, the product must be put into a safe operating condition.

Pressure regulators and pressure control panels are equipped as standard with an integrated relief valve to protect the armatures. The user must ensure there is a suitable safety device installed downstream, if not already included with the equipment as standard.



NOTICE

The pressure relief valve or the over-pressure valve are used to blow out gas that must be conveyed away via a non-permitted pressure rise.

They do not function as a safety valve for the entire gas supply system.



NOTICE

An Acetylene Safety Device (ASG) serves the purpose of preventing an impermissible rise in inlet and/or outlet pressure (caused, for example, by a malfunction of the pressure regulator or by acetylene decomposition) and consequently possible damage to the entire acetylene supply system by shutting off the high-pressure supply line.



⚠ CAUTION

Overpressure in downstream armatures, pressure vessels and pipelines in the event of failure of the pressure regulator and its outlet pressure protection

To protect downstream armatures, pressure vessels and pipelines against excess pressure, a safety device corresponding to the operating firm's regulations must be installed.

3.4 Qualification of the operating and maintenance personnel

The intended user group is the system operator (user of the system) and the system maintenance personnel.

Every person working on the system must be familiar with the functions and dangers associated with the overall system. Instruction on the system is to be documented in writing.

Maintenance and repair work should only be carried out by specially trained personnel.

All operators, as well as personnel who regularly enter the area, must be trained on a minimum of the following topics:

- Alarm rules at the site and conduct in the event of malfunctions and leaks
- Basic functions of the product
- User manual
- System documentation incl. manufacturer documentation
- Position of the safety devices
- Safety data sheets on the process gas used
- Personal protective equipment

In addition, operators must have the requisite physical and mental skills to operate and maintain the equipment.

Persons who do not meet this requirement (e.g. visitors), must not remain alone in the overall system.

Operating personnel must use appropriate personal protective equipment for the activities to be performed and the associated environmental hazards. The operational instructions and the specifications of the employers' liability insurance associations and the safety data sheets must be complied with.

4 Design and function

4.1 Design

Illustration of the pressure control panel with gas cylinder connected

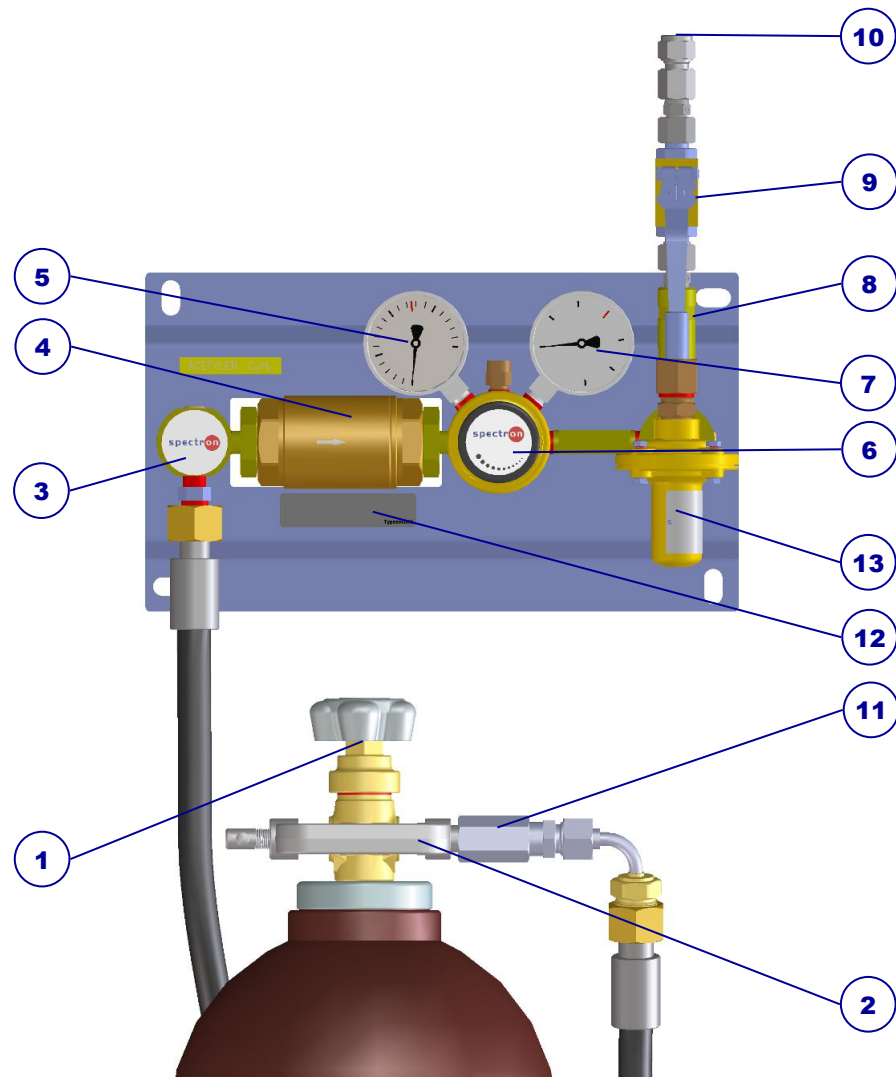

Illustration 1: BT2000AC-SSE design

Pos.	Designation	Short name	Connection
1	Process gas source valve		
2	Cylinder connection incl. plug		Cylinder connection (see label)
3	High pressure connection block	HPI	
4	Quick-action valve	ASG / SSE / KH	
5	Pre-pressure gauge	PG P1	
6	Pressure regulator	PR	
7	Outlet pressure gauge	PG P2	
8	Flashback arrestor	FS	
9	Process line isolation on low pressure side	PLI	

10	Process gas connection	
11	Gas cut-off valve	
12	Label	
13	Over-pressure valve	SV73

4.2 Functional description

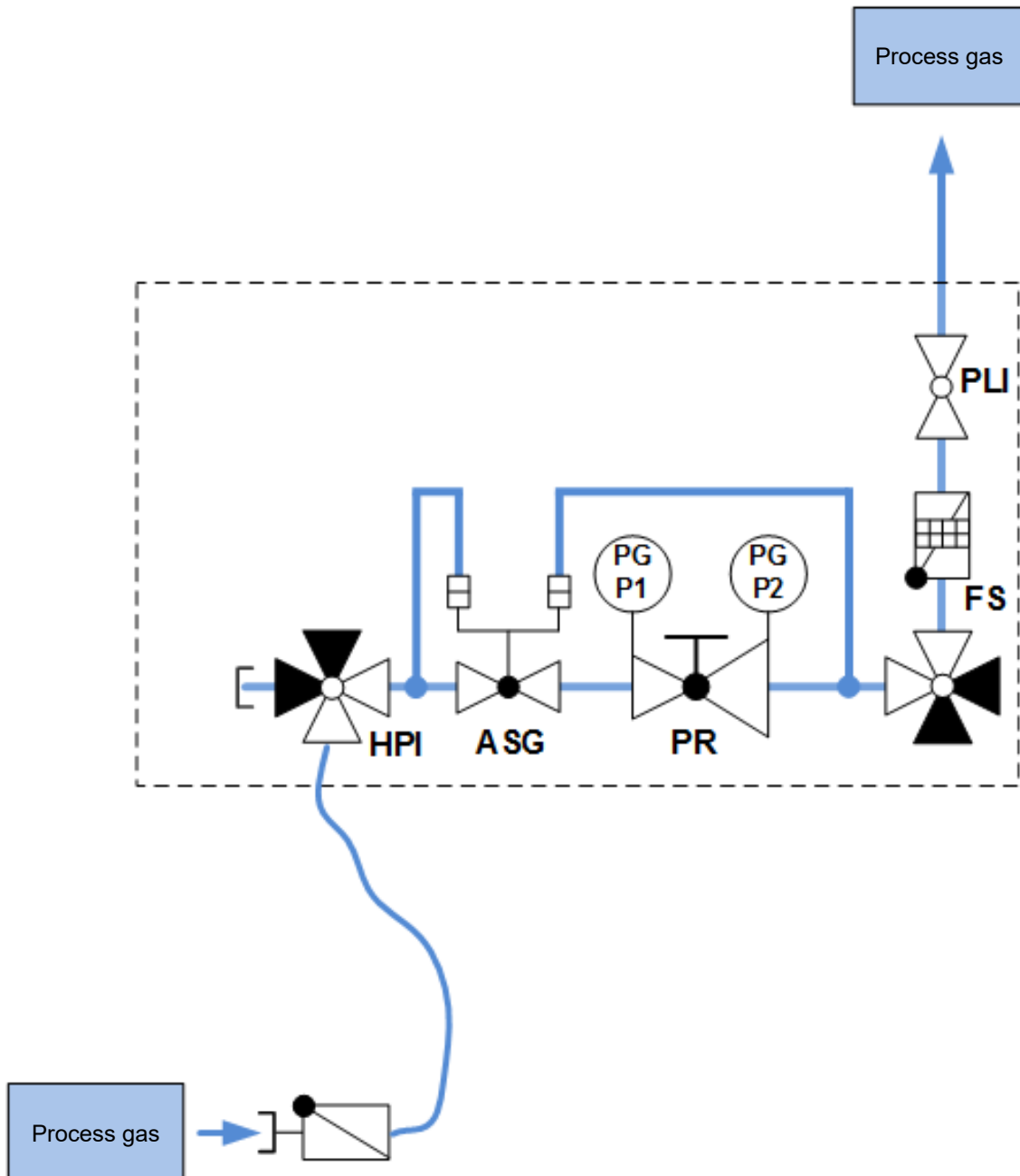

Illustration 2: BT2000AC-ASG P&ID

The intended use of the Pressure control panel BT2000AC is the expansion of a gas from a gas source and the distribution of the gas with adjustable outlet pressure.

Pressure reduction is performed by the pressure regulator. It is equipped with one pressure gauge to display the inlet pressure and the outlet pressure. The outlet pressure is set to the desired value using the handwheel on the pressure regulator and is not permitted to exceed a defined maximum value given on the label.

In the case of the single-stage Pressure control panel present here, the set outlet pressure does not remain completely constant as the inlet pressure changes, and instead rises slightly as the inlet pressure decreases (e.g. caused by a draining cylinder).

Especially in the case of acetylene, this increase in the outlet pressure is taken into account by the manufacturer in the limitation setting of the maximum possible pressure setting value, so that the outlet pressure cannot exceed the maximum permissible 1.5 bar for the low-pressure range in the event of no actual acetylene inlet pressure occurring.

For the safe execution of the main task, the Pressure control panel is equipped with other components in addition to the pressure regulator. The quick-action valve is located upstream of the pressure regulator in terms of flow. This can be an acetylene safety device ASG, an automatic quick-acting valve SSE or a manual quick-acting valve KH (ball valve).

The ASG safeguards both the high-pressure section and the low-pressure section of the acetylene supply system against the exceeding of predefined response pressures. It prevents acetylene from escaping.

The ASG is a component with safety function and can completely replace a safety valve or an over-pressure valve.

The ASG is equipped with an automatic shut-off valve controlled by the inlet pressure and the outlet pressure sides. This valve closes if one of the predefined response pressures is exceeded, thus interrupting the gas supply in the high-pressure area. A display element indicates when the shut-off valve is closed. The valve remains closed even if the pressures within the gas supply system fall below the response pressures of the ASG again. The shut-off valve can only be opened and the ASG enabled via a manually operated bleed screw. The gas supply system can then be operated in normal mode again.

The automatic quick-acting device SSE closes when acetylene decomposition occurs and thus prevents its propagation into the Pressure control panel and into the line network. After being triggered, the SSE must be replaced.

The manual quick-acting shut-off device KH (ball valve) can only be closed via manual operation.

Downstream of the pressure regulator, a flashback arrestor and an optional ball valve are installed to shut off the outlet of the Pressure control panel and disconnect it from the line network.

The flashback arrestor protects the Pressure control panel against problems arising out of the line network, such as backflowing gas, flame setbacks, flame breakdown, acetylene decomposition or other inadmissible heat input.

4.3 Technical data



NOTICE

The technical data can be taken from the data sheet for the relevant product. If this is not available, you can view and download it at www.spectron.de.

The maximum input and output pressures and the gas type are given on the identification or label.

4.4 Boundaries and interfaces

The scope of supply includes the product as described in the "Design [▶ 13]" chapter. The transfer points to process gas, exhaust air and auxiliary media (incl. power supply) are the connections on the pressure control panel or product.

The following areas and functions have not been included in the scope of supply from Spectron:

- other systems, lines and installations of the overall system
- Process gas source
- Exhaust air (this applies in particular to foreseeable problems, e.g. failure of the exhaust air system)
- Supply of auxiliary media (compressed air, purge gas)
- Power supply
- Lighting
- Controller

5 Installation

5.1 General information



⚠ CAUTION

Injury or damage in the event of incorrect assembly or disassembly

Special steps are required for assembly and disassembly work on the product. Personal injuries and damage to the product are possible.

- a) Assembly and disassembly work may only be carried out by the installation engineer or appropriately skilled specialist companies and persons.
- b) The product is not permitted to be re-used following disassembly. All components must be disposed correctly.

Depending on the type of gas, different requirements apply to the installation space of gas supply systems. It is essential to observe the legal regulations and trade association regulations, and the information in the safety data sheets.

Familiarise yourself with the necessary work steps (see "Installation work [▶ 17]") and prepare the necessary tools.

See also

- 📖 Functional description [▶ 14]

5.2 Installation work

5.2.1 Installation

The pressure control panel can be fastened in a gas cylinder cabinet or to the room wall directly with screws or using C-mounting rails.

5.2.2 Connecting the incoming and outgoing lines

All lines must be connected in accordance with the applicable standards and specifications and tested with purge gas (pressure test and leak test). The specifications on dimensioning of the connections are described in the "Design [▶ 13]" chapter.

5.3 Checking the system

Before beginning the test, ensure that the controller (if present) is ready for operation and is in manual mode.

5.3.1 Pressure test with purge gas

For the pressure test, the Pressure control panel BT2000AC, inert gas (non-reactive) gas is used (connect to HPI). Ensure that the required pressure is present and there is a valve present for shutting off the purge gas (PGI).

If no process gas shut-off valve PLI is present in the outlet of the pressure control panel, the complete line network is tested to the consumer and then purged. This must be carried out via an exhaust gas valve on the consumer. To do this, refer to the system documentation for the consumer.

1. Close PLI and fully depressurise the pressure regulator by turning of the handwheel anti-clockwise as far as it will go.
2. Open valve PGI to build up pressure in the system (1.5 bar).
3. Slowly open the pressure regulator and build up pressure.
4. Wait until the pressure has been built up and close the PGI valve.
5. Check whether the displays on PG P1 and PG P2 are identical. If both pressure gauges show the same pressure, release the pressure on the pressure regulator. If the values do not match, check the pressure regulator setting and readjust if necessary.
6. Leave the pressure for 10 minutes.
7. After 10 minutes have elapsed, check that the values on PG P1 and PG P2 still match and whether the pressure has remained constant.
8. If there is no change, release the pressure control panel via PLI and close all valves.

If the pressure has reduced, perform a leak test to check where the gas is escaping, repair the connection and repeat the pressure test.

After a successful low pressure test, a high pressure test (at least 18 bar) is carried out.

1. Close PLI and fully depressurise the pressure regulator by turning of the handwheel anti-clockwise as far as it will go.
2. Open valve PGI to build up pressure in the system (at least 18 bar).
3. Wait until the pressure has been built up and close the PGI valve.
4. Mark the displayed value on PG P1, and leave the pressure for 10 minutes.
5. After 10 minutes have elapsed, check that the value on PG P1 has remained constant.
6. If there is no change, slowly open the pressure regulator and release the pressure control panel via PLI and close all valves.

If the pressure has reduced, perform a leak test to check where the gas is escaping, repair the connection and repeat the pressure test.

The line network can then be purged clear up to the consumer.

6 Commissioning

6.1 Preparations for commissioning

The commissioning of the pressure control panel may only be carried out after the integration into the inventory has been completed. Commissioning is not permitted until the incomplete machine has been installed into a complete machine and this corresponds to the provisions of the EU Machinery Directive and the EC Declaration of Conformity according to appendix II A.

Before putting the equipment into operation for the first time, the entire pressure control panel must be purged via the PLI valve right up to the process. It is imperative to adhere to the direction of the gas flow when doing this. You must not purge counter to the usual direction of flow (from the tapping point to the pressure control panel), since this can flush debris resulting from the installation work, for example, back into the pressure regulator (PR).

The connecting threads and connecting surfaces of the gas source valves as well as the sealing rings must be checked to ensure that they are in perfect condition.

Always turn shut-off valves as far as the stop when opening or closing them.

Valves and ball valves must always be moved slowly and by no means abruptly.

Make sure that:

- the fittings are marked for the corresponding gas type,
- all protective caps have been removed,
- the assembly has been correctly carried out and a pressure test has been performed,
- all ball valves and valves are closed (the red marking is visible in the handwheel window) and
- the pressure regulator has been depressurised (if possible),
- the on-site exhaust gas system (if present) is functional at all times and is in operation,
- all shut-off armatures are checked for loose connections and
- the controller (if fitted) is in operation.

6.2 Procedure for commissioning

6.2.1 Connecting the process gas source

Connect the hoses. Proceed as described in the instruction manual for the respective hose.

1. Place the process gas source in front of the bracket and secure with the safety chain.
2. Remove and retain the protective cap and sealing nut on the process gas source.
3. Remove the plug from the gas connection.
4. Check connection thread and sealing. A new sealing must be used for each gas source exchange.
5. Screw the gas port onto the gas source valve by hand and tighten it gas-tight with a spanner as required.
6. Perform a leak test as pressure or leak test. The HPI remains closed in this process (see "Exchanging the process gas source [► 21]").

The HPI may not only be the high-pressure connection block, but in some versions may also consist of a ball valve or shut-off valve.

7 Operation

7.1 General information on operation

During regular operation, the system will be in supply mode.

The procedure for decommissioning and recommissioning for extended system standstills is described in the "Decommissioning and recommissioning [▶ 27]" chapter.

7.2 Gas supply interruption

7.2.1 Interruptions to operation for less than 48 hours

For short interruptions to operation (less than 48 hours), the valve on the process gas source and valve PLI or a valve on the consumer can be closed. No other shut-off and safety measures are required.

7.2.2 Interruptions to operation for more than 48 hours

For longer interruptions to operation (over 48 hours), the following steps must be carried out:

1. Close all valves and fully depressurise the pressure regulator by turning the handwheel anti-clockwise as far as it will go.
2. Open valve PLI to reduce the pressure.
3. Close valve PLI.
4. The valve on the consumer remains closed, meaning there is excess pressure in the lines.

7.2.3 Putting the pressure control panel into a safe condition

In the event of interruptions in operation for more than 5 days or pending maintenance or servicing, the pressure control panel must be put into a safe condition. First carry out the steps "Interruptions to operation for more than 48 hours [▶ 20]".

The process gas source must be connected during flushing (see "Connecting the process gas source"). Also observe the "Preparations for commissioning [▶ 19]" chapter.

To ensure high gas purity, pressure purging is to be performed as described below.

1. Close all valves and fully depressurise the pressure regulator by turning the handwheel anti-clockwise as far as it will go.
2. Open slowly valves PGI and HPI to build up pressure in the system.
3. Slowly open the pressure regulator and build up pressure.
4. Close valve PGI.
5. Open valve PLI to reduce the pressure in the process gas line, then close it again. Repeat steps 2 to 5 depending on the gas type at least 3 times to remove impurities or foreign substances without leaving a residue. The pressure regulator remains pressurised.
6. Close all valves.
7. Fully depressurise the pressure regulator by turning the handwheel anti-clockwise as far as it will go.

7.3 Exchanging the process gas source



⚠ WARNING

Gas source exchange

If a gas source exchange is performed incorrectly, gas leakage and poisoning of persons may occur.

- a) The gas source exchange are to be carried out by trained specialist personnel and never unattended.
- b) A pressure test must be conducted after each gas source exchange.
- c) For each gas source exchange, a new seal suitable for the used gas is to be used.
- d) Wear the personal protective equipment prescribed in the risk assessment.

With each gas source exchange, check the port for leak-tightness. We strongly recommend replacing the seal every time the gas source is exchanged. Always turn the shut-off valves slowly and as far as the stop when opening or closing them!

Removing the empty process gas source:

1. Close the process gas source valve.
2. As the pressure control station does not have its own pressure relief device, the remaining acetylene gas present in the system and under pressure must be discharged via the consumers.
When this pressure relief process is completed, the two pressure gauges on the pressure regulator must display the value "zero". Ensure this with a visual inspection!
3. Depressurise the pressure regulator by turning the handwheel and close the ball valve in the pressure control panel outlet.
4. Disconnect the process gas source connection.
5. Mount the sealing nut on the gas source valve and protective cap on the process gas source.
6. Identify, secure and remove the empty process gas source.

If hoses with an integrated check valve are used to connect the pressure control station to the cylinder valve, steps 2 and 3 can be omitted.

Connecting the new process gas source:

1. Provide new process gas source, position in front of the bracket and secure using the safety chain.
2. Remove and retain the protective cap and screw plug.
3. Check the port thread and sealing; a new sealing must be used each time the gas source is exchanged.
4. Screw the process gas connection onto the gas source valve by hand and tighten it gastight.
5. Open the process gas source valve, build up pressure, and close it again. Check using leak test spray whether the process gas port is leak-tight.
6. Open the process gas source valve.
7. Open valve HPI. In the case of two-sided pressure control panels with manual switchover, keep the HPI valve closed, and do not open it until the supply side has to be changed again.
8. Set the pressure regulator to the required outlet pressure in increments.
9. Slowly open the PLI.

The pressure control panel is ready for supply.

8 Maintenance, cleaning and repairs

8.1 General information on maintenance



⚠ WARNING

Noise emission

When working on pressurised pneumatic supply, significant noise emission can occur. Acute and chronic loss of hearing may result.

- a) Never perform work on the pressurised pneumatic supply without hearing protection.
- b) Only replace the silencers when the supply is unpressurised.



⚠ WARNING

Incorrect operation

Incorrect operation of the system, e.g. due to instruction errors, can lead to personal injury or damage to the system.

- a) Access to the user manual by the operating and maintenance personnel must be absolutely ensured at all times.
- b) A copy of the system documentation including the user manual must therefore be kept either on the system or in a suitable and accessible location.



⚠ WARNING

Working on the product

If an accident occurs when working on the product, there is a considerable risk of injury.

- a) Never work on the product unattended or unannounced.
- b) Observe the site safety rules and permission procedure.



⚠ WARNING

Maintenance

Incorrect maintenance or maintenance work performed at the incorrect time can result in damage to the system or injury to persons.

- a) To avoid static charges, do not clean the product using dry cloths. Use damp cotton cloths.
- b) The maintenance intervals are to be specified by the system operator as part of its risk assessment.
- c) Observe the maintenance intervals and maintenance guidelines from the manufacturer and the applicable guidelines.
- d) Components may only be replaced by spare parts of the same design. The specifications of the component manufacturers must be complied with during installation.



⚠ CAUTION

Injury or damage in the event of incorrect assembly or disassembly

Special steps are required for assembly and disassembly work on the product. Personal injuries and damage to the product are possible.

- a) Assembly and disassembly work may only be carried out by the installation engineer or appropriately skilled specialist companies and persons.
- b) The product is not permitted to be re-used following disassembly. All components must be disposed correctly.



NOTICE

Lighting

Incorrect switching actions or confusion can occur due to inadequate lighting.

- a) Ensure sufficient lighting in accordance with the statutory regulations.

Correctly performed and timely maintenance increases the service life, ensures availability and helps to avoid undesirable downtimes. Depending on the gas type, the components are subject to different maintenance intervals. Observe the stipulations from the applicable directives.

Servicing and maintenance measures are only permitted to be carried out by competent specialist companies and persons.

Maintenance work should be documented by the operator. The documentation should indicate who carried out which work and when (proof of maintenance).

It is only permitted to use original spare parts or equivalent spare parts as well as suitable tools:

The recommended maintenance and test intervals are to be observed! (Also observe the manufacturer's documents)

The causes of possible defects are to be investigated, e.g. damage, unusual noises, overheating, etc.

Before beginning maintenance work, the pressure control panel must be purged (see "Interruptions to operation for more than 48 hours [▶ 20]"). After completing the works, a re-commissioning process must be carried out (see "Commissioning [▶ 19]").

8.2 Flushing the process gas into the pressure control panel

1. Close all valves and fully depressurise the pressure regulator by turning the handwheel anti-clockwise as far as it will go.
2. Open the process gas source valve and then the HPI valve, so to fill the entire area in which the process gas is to penetrate (pressure build-up).
3. Now open valve PLI.
4. Slowly set the pressure regulator to the required outlet pressure.

In this process, the process source pressure and the gas type properties are to be taken into account.

The pressure control panel is now in a condition ready for operation.

If operation is not to be continued following the flushing process, proceed in accordance with "Gas supply interruption [▶ 20]".

8.3 Regular maintenance work and cleaning

For components in which the tests reveal wear or even malfunctions, repairs or component replacement must be carried out by competent specialist companies and persons.

Components	Test	Interval
Filter	Replace filter	Replacement with insufficient flow rate
All	Visual inspection for corrosion, damage and correct fastening Functional test Leakage test	At least annually and before each commissioning process
Earthing	Visual inspection for damage and correct fastening	At least annually

The product should be cleaned on a regular basis. Heavy soiling can lead to malfunctions.

Only clean the product as necessary using a damp, lint-free and clean cloth, without cleaning agent.

9 Repair

9.1 General information on repair work



⚠ WARNING

Noise emission

When working on pressurised pneumatic supply, significant noise emission can occur. Acute and chronic loss of hearing may result.

- a) Never perform work on the pressurised pneumatic supply without hearing protection.
- b) Only replace the silencers when the supply is unpressurised.



⚠ WARNING

Incorrect operation

Incorrect operation of the system, e.g. due to instruction errors, can lead to personal injury or damage to the system.

- a) Access to the user manual by the operating and maintenance personnel must be absolutely ensured at all times.
- b) A copy of the system documentation including the user manual must therefore be kept either on the system or in a suitable and accessible location.



⚠ WARNING

Working on the product

If an accident occurs when working on the product, there is a considerable risk of injury.

- a) Never work on the product unattended or unannounced.
- b) Observe the site safety rules and permission procedure.



⚠ CAUTION

Injury or damage in the event of incorrect assembly or disassembly

Special steps are required for assembly and disassembly work on the product. Personal injuries and damage to the product are possible.

- a) Assembly and disassembly work may only be carried out by the installation engineer or appropriately skilled specialist companies and persons.
- b) The product is not permitted to be re-used following disassembly. All components must be disposed correctly.



NOTICE

Lighting

Incorrect switching actions or confusion can occur due to inadequate lighting.

- a) Ensure sufficient lighting in accordance with the statutory regulations.

The objectives of the repair are:

Detect and assess causes of malfunction

Rectify faults and restore operational readiness

Repairs to the product may only be performed by the manufacturer or specialist personnel instructed on the system.

Work on electrical system parts may only be performed by a qualified electrician.

Before beginning work, the pressure control panel must be purged (see "Flushing through to the process"). After completing the works, a re-commissioning process must be carried out (see "Commissioning [▶ 19]").

9.2 Troubleshooting and fault rectification

Fault	Possible cause	Remedy
Outlet pressure too low	Process gas source empty	Check inlet pressure on the pressure regulator and change the process gas source if necessary
Vibration noises in the pressure regulator	Pressure regulator faulty	Replace pressure regulator
Pressure regulator frozen	Flow rate too high	Reduce flow rate or use gas preheater if possible
System pressure cannot be set to the desired value	Pressure regulator faulty	Replace pressure regulator
	System pressure outside the intended system pressure	Only operate the system at the intended range
Flow insufficient or fluctuating	Inlet pressure of the process gas too low	Increase inlet pressure
	Valve faulty	Replace faulty valve
	Filter loaded	Change filter
Relief valve, over-pressure valve, safety valve or burst disc are discharging gas	Impermissible pressure rise in the outlet pressure range	Close all valves and check pressure control panel
HPI valve cannot be opened or closed	Pneumatic pressure too low	Check pneumatic pressure
	Compressed air hose ripped	Replace compressed air hose out
Leak	Connection leaking	Flush pressure control panel clear and perform pressure test and leak test

10 Decommissioning and recommissioning

10.1 Decommissioning

The gas supply via the pressure control panel can be interrupted without additional risks. If the pressure control panel remains unused or disassembled for an extended period, a decommissioning process must be carried out.

In principle, decommissioning must be carried out in the following order:

1. Interrupt gas supply (see "Gas supply interruption [▶ 20]").
2. Disconnect the process gas source from the pressure control panel.
3. Seal all open screw connections tightly (e.g. plug on process gas port).
4. Flushing through to the process (see "Flushing through to the process").
5. Close all valves.
6. Switch off controller.

10.2 Recommissioning

The recommissioning of the pressure control panel must be carried out in accordance with the stipulations in the "Commissioning [▶ 19]" chapter.

11 Dismantling and disposal

11.1 General information on dismantling



! WARNING

Noise emission

When working on pressurised pneumatic supply, significant noise emission can occur. Acute and chronic loss of hearing may result.

- a) Never perform work on the pressurised pneumatic supply without hearing protection.
- b) Only replace the silencers when the supply is unpressurised.



! CAUTION

Injury or damage in the event of incorrect assembly or disassembly

Special steps are required for assembly and disassembly work on the product. Personal injuries and damage to the product are possible.

- a) Assembly and disassembly work may only be carried out by the installation engineer or appropriately skilled specialist companies and persons.
- b) The product is not permitted to be re-used following disassembly. All components must be disposed correctly.



NOTICE

Lighting

Incorrect switching actions or confusion can occur due to inadequate lighting.

- a) Ensure sufficient lighting in accordance with the statutory regulations.

Before dismantling and disposal of the pressure control panel, it must be taken out of operation and purged. The pressure control panel must then be disconnected from the auxiliary media supply.

The dismantling process is to be carried out in the following order:

1. Purging of the pressure control panel and decommissioning.
2. Disconnect the pressure control panel from the gas supply system.
3. Disconnect the pressure control panel from the process.
4. Remove the pressure control panel – to do so, please refer to the "Installation [▶ 17]" chapter.
5. Seal all ports on the pressure control panel.
6. Pack the pressure control panel.

11.2 Returns

If products are returned to Spectron for checking, maintenance or repair, it is essential to purge them with inert gas (see also "Flushing through to the process"). A check can only be undertaken by Spectron if the decontamination declaration (<https://www.spectron.de/sites/default/files/2020-08/Declaration%20of%20decontamination.pdf>) has been duly completed.

11.3 Disposal

Dismantling and disposal must be carried out in accordance with the official and legal requirements at the site of the system. The operator must produce a risk assessment and work instructions before dismantling. A piece of equipment may only be disposed of when the decontamination declaration (<https://www.spectron.de/sites/default/files/2020-08/Declaration%20of%20decontamination.pdf>) has been provided, completed in full.



Gas control on a high level



Spectron Gas Control Systems GmbH
Fritz-Klatte-Str. 8
D-65933 Frankfurt
Tel: +49 (0)69 38016-0
Fax: +49 (0)69 38016-200
info@spectron.de
www.spectron.de