

Panel / Line regulator M52-6

spectrolab



Line pressure regulator LM52-6



Example: PM52 panel surface mounted

Product features

- Single-stage line pressure regulator or for panel and panel surface mounting with compensated main valve and anti-vibration device
- For non-corrosive gases and gas mixtures up to quality 6.0
- 6 ports for flexible and individual configuration
- Very high control accuracy
- Metal-to-metal seal to atmosphere
- Central filter
- Approved for use with oxygen
- New laboratory-style design
- Suitable for ECD-applications
- Pressure regulator can be evacuated

Technische Daten

Inlet pressure P_1	max. 300 bar
Max. outlet pressure P_2	1,5 / 4 / 10 / 20 bar
Materials	
Body:	chrome-plated brass
Diaphragm:	Hastelloy C276
Valve seat:	PA
Soft goods:	FPM, EPDM
Filter:	stainless steel 1.4404
In- / outlets	1/4"-NPT female
Temperature range	-20°C to +60°C
Leakrate (to atmosphere):	≤ 10 ⁻⁸ mbar l/s He
(via seat):	≤ 10 ⁻⁶ mbar l/s He
C_v value	0,16
Weight	1,1 kg

Flow curves M52

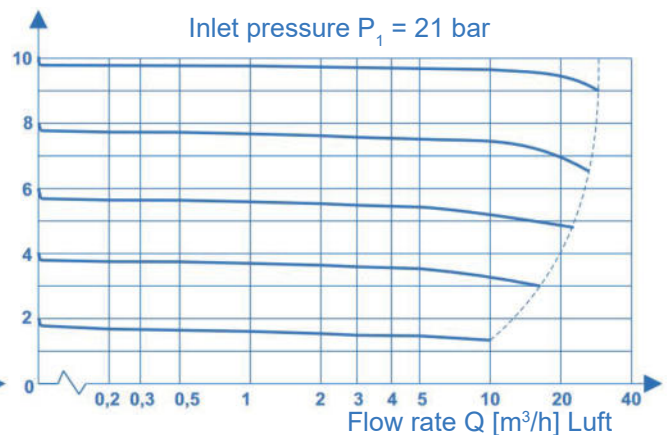
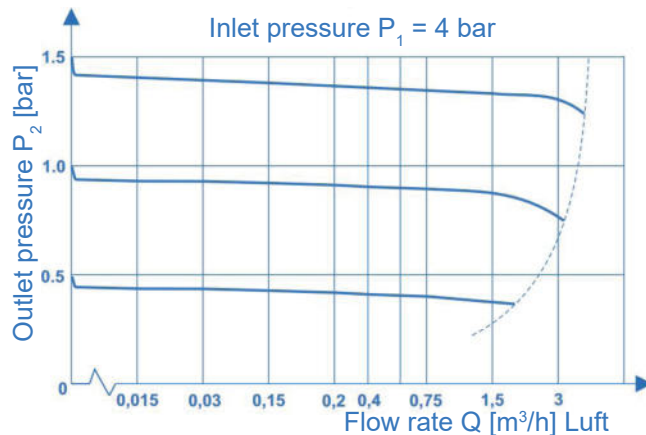

Panel / Line regulator M52-6

spectrolab

Dimensions M52-6

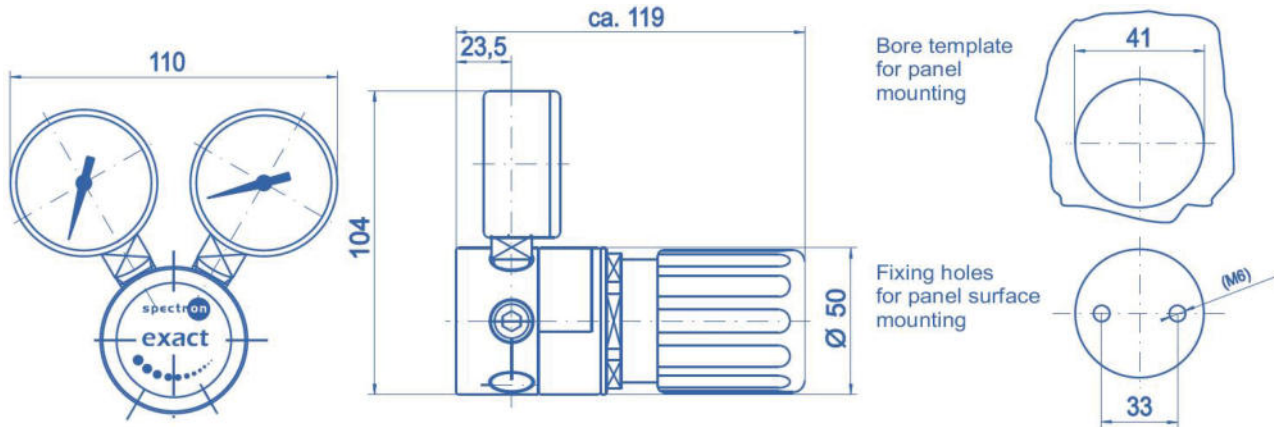

Ordering information:

Pressure regulators M52-6

In- / outlets

- CM 1/4** 1/8" / 1/4" / 1/2"-compression fitting (brass)
- CM 6** 3 / 6 / 8 / 10 / 12 mm - compression fitting (brass)
- CE 1/4** 1/8" / 1/4" / 1/2"-compression fitting (stainless steel)
- CE 6** 3 / 6 / 8 / 10 / 12 mm - compression fitting (stainless steel)
- B** plug
- A** relief valve - 1/4"-NPT-F ($P_2 \leq 100$ bar)
- K** contact pressure gauge
- M** pressure gauge
- 0** 1/4"-NPT-F (port only)

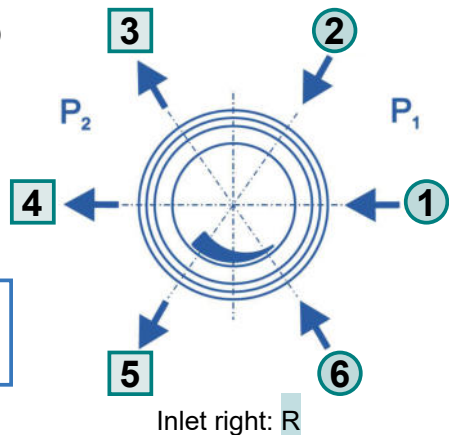
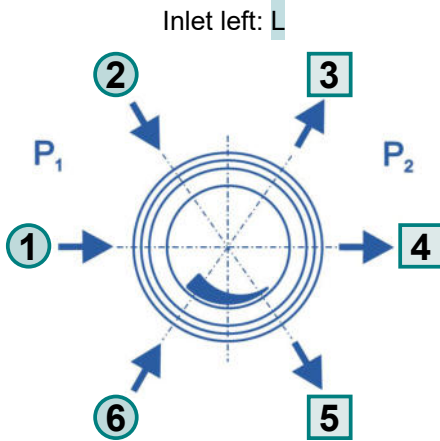

LM52 - L - 300 - 20 - 1 - 2 - 3 - 4 - 5 - 6 - H2

Type

- L** Line regulator
- P** Panel regulator

Inlet

- L** left
- R** right

Inlet pressure P_1

- 100** max. 100 bar
- 200** max. 200 bar
- 300** max. 300 bar

Outlet pressure P_2

- 1,5** max. 1,5 bar
- 4** max. 4 bar
- 10** max. 10 bar
- 20** max. 20 bar

Gas type

Please specify gas type!

For inlet pressure up to 50 bar and outlet pressure of max. 1,5 or 4 bar please use M51.