

Cylinder pressure regulator FE45

spectro**cem**

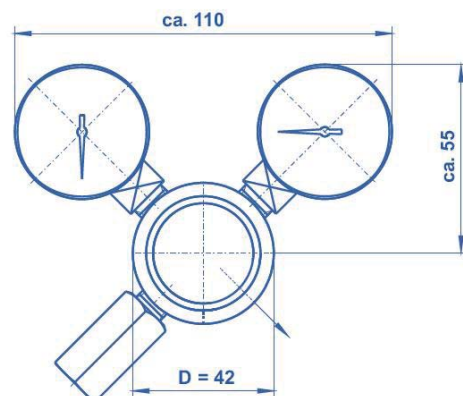

Pressure regulator FE45



Main dimensions

Product features

- Single-stage cylinder pressure regulator with compensated main valve
- Simple and safe gas withdrawal from gas cylinders, for corrosive gases and gas mixtures up to quality 6.0
- Very high control accuracy due to compensated main valve
- Compact design, light weight
- New laboratory-style design
- Ergonomically designed
- Including manual cylinder connection for non metal-to-metal sealing cylinder connection)
- Suitable for ECD applications
- Integrated relief valve
- Hastelloy diaphragm
- Minimised gas wetted surface

Technical data

Inlet pressure P_1	max. 230 bar
Outlet pressure P_2	max. 1,5 / 4 / 10 bar
Materials	
Body:	SS 1.4404 (316L)
Diaphragm:	Hastelloy C276
Valve seat:	PCTFE*
Inlet	Cylinder connection
Outlet	1/8"-NPT female
Temperature range	-20°C to +60°C
Leak rate (to atmosphere):	≤10 ⁻⁸ mbar l/s He
(via valve seat):	≤10 ⁻⁶ mbar l/s He
Weight	520 g

* Other valve seat materials such as PVDF upon request

Flow curves FE45

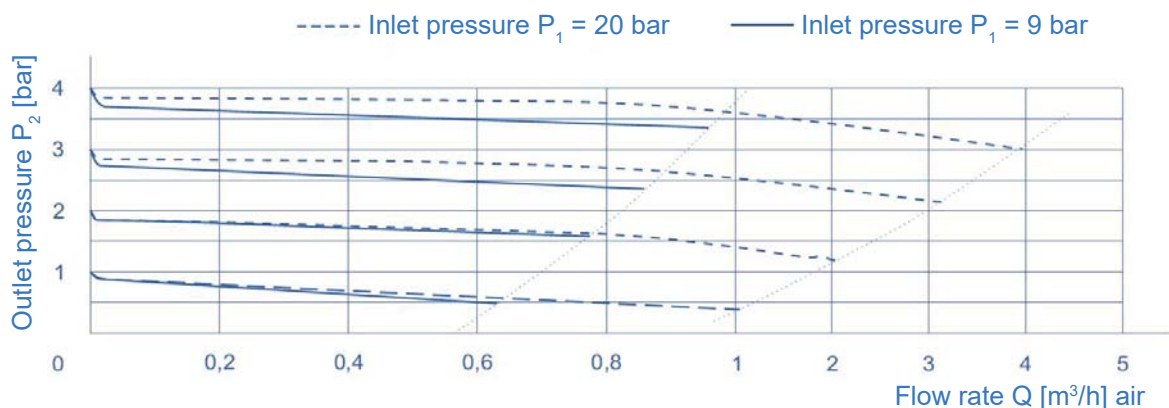

Cylinder pressure regulator FE45

spectro**cem**

Dimensions FE45

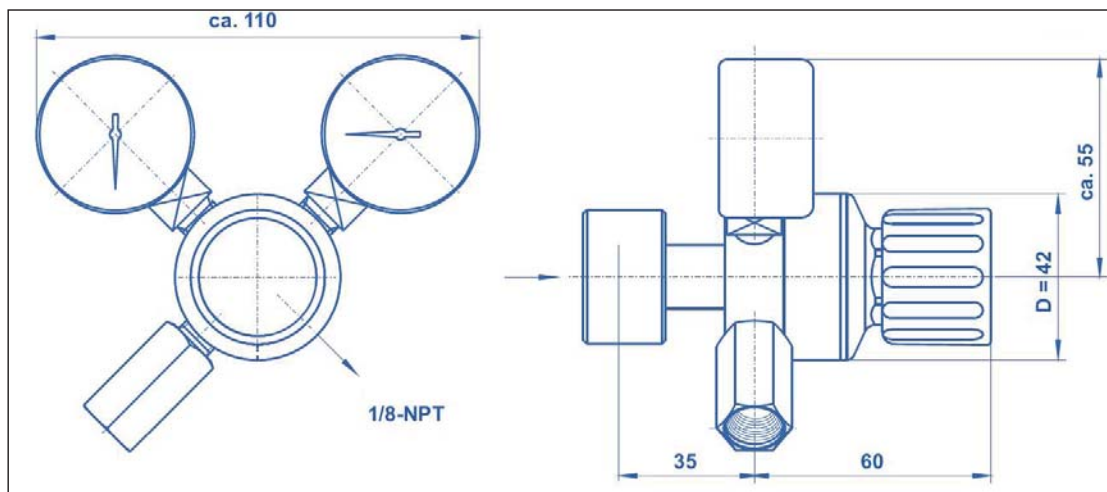

Ordering information: Pressure regulator FE45

FE45 - 230 - 4 - DIN1 - H2

Inlet pressure P_1

230 max. 230 bar

Outlet pressure P_2

1,5 max. 1,5 bar

4 max. 4 bar

10 max. 10 bar

Type of gas

Please specify type of gas for selection of sealing materials

Cylinder connection

Detailed description of the cylinder connection (e.g. BS no. 3)

Specifications:

- Spectrocem components guarantee maximum quality by using high grade materials and a quality assurance program acc. to ISO 9001.
- All components which come into contact with the medium are cleaned in an ultrasonic cleaning system (CFC-free) with the special cleaning process Spectroclean® and are then baked out.
- Spectrocem components undergo a 100% function- and Helium-leak test.