

Performance diagram



If gas type, inlet pressure, outlet pressure and flow rate are known for a particular application, then the required performance factor "L" can be found in the performance diagram. The performance factor is the characteristic of all Spectron pressure regulators and allows a safe and easy selection of the suitable pressure regulator.

The performance diagram contains five variables:

Outlet pressure P [bar], Inlet minus outlet pressure ΔP [bar], flow rate V_n [m³/h] at standard conditions acc. to DIN 1343 ($P_n = 1.01325$ bar and $T_n = 0^\circ\text{C}$), gas type (density ρ at 0°C and 1.013 bar [kg/m³]), performance factor "L".

If the flow rate is only given at operating conditions, it must be converted to the flow rate at standard conditions first.

The conversion of a flow rate (at room temperature) may be done according to this equation:
 $1 \text{ m}^3 \text{ gas at standard conditions} = 1 \text{ m}^3 \text{ gas at operating conditions} \times \text{pressure (absolute, bar} + 1)$.

Four out of the five variables must be known, so that the fifth may be seen in the diagram.

For gas mixtures the density of the mixture at standard conditions must be used in order to read the flow rate or the required performance factor from the diagram.

The performance factor "L" introduced by Spectron is the characteristic for every Spectron-regulator; it replaces the formerly used performance tables and allows for a safe and easy selection of the pressure regulator suitable for the application in question.

The performance factor is the logarithm of the cross-sectional area of the flow in the regulating valve of the pressure regulator taking also into account the friction and the contraction of the flow. If you know the regulator type, its performance factor and the gas type, then the flow rate for various in- and outlet pressure values may be read from the diagram.

Example I to find the performance factor "L"

(type of pressure regulator unknown)
 If the type of pressure regulator for an application is unknown, the required performance factor for the regulator can be found from the gas type, the inlet pressure, the outlet pressure and the flow rate. Notice that the pressure regulator must be designed for the worst case, i. e. the minimum available in-/outlet pressure difference. In case of doubt it is advisable to find the required performance factor for several possible operating parameters and to select the pressure regulator according to the greatest value of "L".

Operating parameters:
 Inlet pressure varying between 30 and 20 bar, outlet pressure adjustable between 8 and 10 bar is required.
 Required flow rate 120 m³/h, oxygen

The pressure regulator design must be done for the worst case, i. e. for the minimum available pressure difference; in this case this would be done for the minimum inlet pressure (20 bar) and the maximum outlet pressure (10 bar), thus pressure difference = 20 - 10 = 10 bar.

For this scenario the performance factor must be determined:

1. Inlet minus outlet pressure = 10 bar, follow the vertical line (A)
2. Outlet pressure = 10 bar, follow the diagonal line (B)
3. Intersection (1)
4. Flow rate = 120 m³/h, parallel to the grid lines diagonally to the top left hand side (D)
5. Gas type line oxygen horizontally to the right (E)
6. Intersection (2)
7. From intersection (1) horizontally to the right (C)
8. From intersection (2) vertically to the top (F) on line (C)
9. Intersection (3)
10. From intersection (3) parallel to the grid lines diagonally to the top right hand side (G)
11. Performance factor L = 6.5

Example II (to find the flow rate; type of regulator and performance factor L = 6.5 are known)

Operating parameters: see example I

1. Inlet- minus outlet pressure = 10 bar, follow the vertical line (A)
2. Outlet pressure = 10 bar, follow the diagonal line (B)
3. Intersection (1)
4. From intersection (1) horizontally to the right (C)
5. Performance factor L = 6.5; parallel to the grid lines diagonally to the left hand side (G)
6. Intersection (3)
7. From intersection (3) vertically down (F)
8. Gas type line oxygen horizontally to the right (E)
9. Intersection (2)
10. From intersection (2) parallel to the grid lines diagonally to the bottom right hand side (D)
11. Flow rate = 120 m³/h

This flow rate is valid for the regulator only, not for the in- and outlet pipework! The dimensions of the pipework has to be checked for sufficient flow capacity separately (see data sheet "Dimensions of pipes and fittings for gases")

Flow rates greater than 10,000 m³/h

- ✎ Finding the flow rate: Reduce known performance factor by 5, then multiply the flow rate from the diagram by 10.
- ✎ Finding the performance factor: Divide known flow rate by 10, then add 5 to the performance factor found from the diagram.

All pressure values are values above atmospheric pressure [bar].



Performance diagram

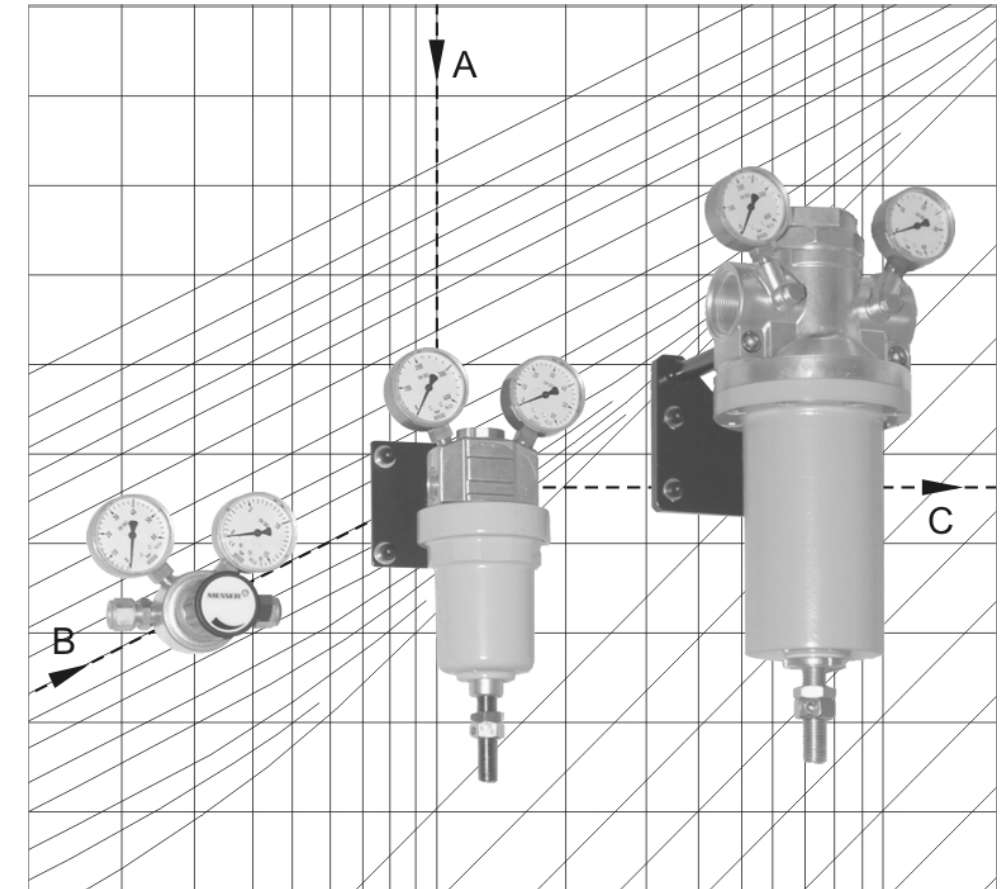

How to find the right pressure regulator



