

Line pressure regulator LM53-2

spectro lab



Line pressure regulator LM53-2

Specifications

- SPECTROLAB-components guarantee maximum quality by using high grade materials and a quality assurance program acc. to ISO 9001.
- All parts in the gas wetted surface area are cleaned in an ultrasonic cleaning system (CFC-free) with the special Cleaning process SPECTRO-CLEAN® and then baked out.
- SPECTROLAB-components undergo a 100% function- and Helium-leak-test.

Product features

- 2-stage diaphragm line pressure regulator with extremely stable outlet pressure and anti-vibration device
- For non-corrosive gases and gas mixtures up to quality 6.0
- 2 ports for flexible and individual configuration
- New laboratory-style design
- Central filter
- Suitable for ECD-applications
- Pressure regulator can be evacuated
- Suitable for inlet pressures up to 300 bar
- Max. outlet pressures 1.5 up to 20 bar
- Light weight
- Compact design
- Approved for use with oxygen
- Simple outlet pressure limitation by handwheel
- Easy to install

Technical data

Type	double-stage
Inlet pressure P_1	max. 300 bar
Outlet pressure P_2	1.5 / 4 / 10 / 20 bar
Materials	
Body regulator, relief valve:	chrome plated brass
Valve seat:	PA
Diaphragm:	Hastelloy C276
Soft goods:	EPDM
Filter:	Sintered bronze
In- and outlets	1/4" NPT-F
Temperature range	-30°C to +60°C
Leak rate (to atmosphere)	1x10 ⁻⁸ mbar l/s He
(via seat)	1x10 ⁻⁶ mbar l/s He
Weight	1.6 kg

Flow curves LM53

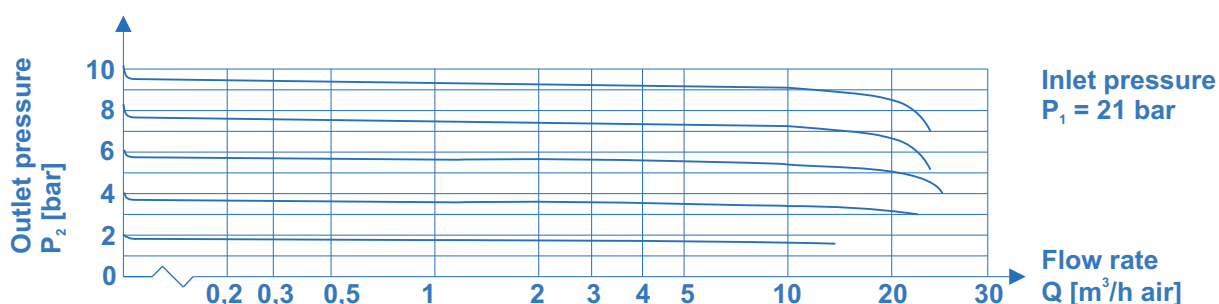

Line pressure regulator LM53-2

spectron lab

Dimensions

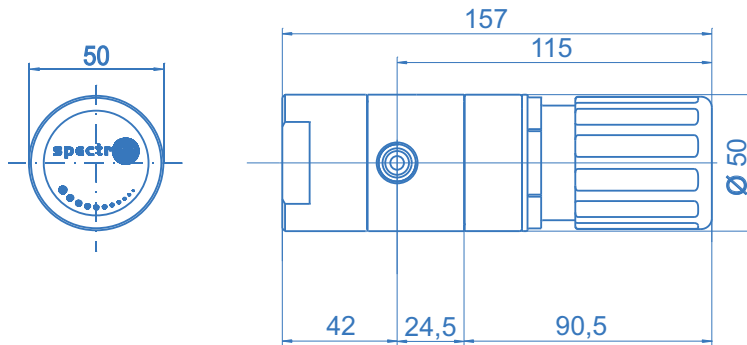

Ordering information:

Line pressure regulator LM53

In- / outlets

CM 1/4	- 1/8" / 1/4" / 1/2"	- OD compression fitting (brass)
CM 6	- 3 / 6 / 8 / 10 / 12	mm compression fitting (brass)
CE 1/4	- 1/8" / 1/4" / 1/2"	- OD compression fitting (stainless steel)
CE 6	- 3 / 6 / 8 / 10 / 12	mm compression fitting (stainless steel)
0	- 1/4" NPT-F	(port only)

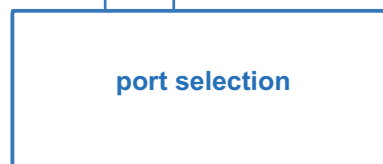
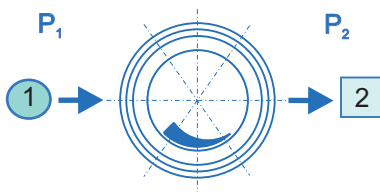

LM53 - 2 - 300 - 20 - 1 - 2 - N2

Inlet pressure P_1

100	- max. 100 bar
200	- max. 200 bar
300	- max. 300 bar

Outlet pressure P_2

1,5	- to 1.5 bar
4	- to 4 bar
10	- to 10 bar
20	- to 20 bar

Type of gas

Please specify type of gas (for selection of valve seat materials)

For inlet pressure up to 50 bar and outlet pressure of max. 1,5 or 4 bar please use M51